



EXAMINATIONS COUNCIL OF ESWATINI
Junior Certificate Examination

CANDIDATE
NAME

CENTRE
NUMBER

--	--	--	--

CANDIDATE
NUMBER

--	--	--	--

CONSUMER SCIENCE

540/02

Paper 2

October/November 2021

Candidates answer on the Question paper.
No additional Materials are required.

2 hours

READ THESE INSTRUCTIONS FIRST

Write your Centre number, candidate number and name on the spaces provided.

Write in **blue** or **black** pen.

You may use an HB pencil for any diagrams.

Do not use staples, paper clips, highlighters, glue or correction fluid.

Do **not** open this Question Paper until you are told to do so.

This Question Paper contains **TWO SECTIONS**, A and B.

Answer **two** Questions from each section.

SECTION A - NUTRITION, FOOD PREPARATION AND HOME MANAGEMENT

SECTION B - CLOTHING & TEXTILES AND LAUNDRY

For Examiners Use	
SECTION A	
SECTION B	
TOTAL MARKS	

This document consists of **14** printed pages and **2** blank pages.

SECTION A

This Section consists of Nutrition, Food Preparation and Home Management.

There are **three** Questions in this section. Answer only **two** Questions.

QUESTION 1

(a) Define the following nutritional terms:

(i) Constipation

.....
..... [1]

(ii) Sedentary worker

.....
..... [1]

(b) Name the nutrient responsible for each of the functions below:

(i) Gives a satiety feel

.....

(ii) Prevents Beri - Beri

.....

(iii) Makes blood

..... [3]

(c) Explain **two** uses of a food pyramid in meal planning.

.....
.....
.....
..... [4]

(d) Discuss how steam is used as a raising agent.

.....
.....
..... [2]

(e) Differentiate between boiling and stewing. Give **two** points for each.

.....
.....
.....
..... [4]

(f) Describe the procedure for testing a fruit for pectin content.

.....
.....
.....
.....
..... [4]

(g) Give **two** reasons for controlling ants in the home.

(i).....
(ii)..... [2]

(h) Describe the procedure for cleaning a kitchen sink.

.....
.....
.....
.....
..... [4]

[Total marks: 25]

QUESTION 2

(a) Define these terms:

(i) Micro nutrients

.....
..... [1]

(ii) Elderly person

.....
..... [1]

(b) Classify the **two** sources of fats with an example for each class.

Class	Example
.....
.....

[4]

(c) Cereals are important foods in our daily diet.

(i) Mention the main nutrient found in cereal foods.

..... [1]

(ii) State **two** reasons why cereals need thorough cooking before they are eaten.

.....
.....
..... [2]

(d) State and explain **two** factors to consider when planning a meal for a manual worker.

.....
.....
.....
.....
..... [4]

(e) Why are the following done during creaming of a cake? Give **one** reason for each.

(i) Sift flour in a bowl.

.....
..... [1]

(ii) Beat an egg lightly and add it gradually to creamed fat and sugar.

.....
..... [1]

(f) Describe the differences between direct and indirect steaming, and give **one** example of a suitable food for each.

.....
.....
.....
.....
..... [4]

(g) State the suitable way of disposing each of the following types of refuse:

(i) Vegetable peels.

..... [1]

(ii) Plastic juice bottles.

..... [1]

(h) Mention **two** advantages of an electric stove.

(i).....

(ii)..... [2]

(i) Explain the care of a glass casserole dish using the following headings:

(i) Handle glass carefully.

.....
..... [1]

(ii) Wrap casserole dish with tissue paper.

.....
..... [1]

[Total marks: 25]

QUESTION 3

(a) Water is very important to life and must be taken with food on a daily basis.

(i) Give **one** food source of water besides beverages.

.....
..... [1]

(ii) Apart from being vital to life, what are the other **two** functions of water in the body?

.....
.....
.....
..... [2]

(b) Explain, in two points, the nutritional requirement for teenagers.

.....
.....
.....
.....
..... [4]

(c) Differentiate between fat - soluble and water - soluble vitamins.

.....
.....
.....
..... [4]

(d) State **two** uses of cheese in food preparation.

(i)
(ii) [2]

(e) Describe the procedure for measuring a level cup of flour.

.....
.....
.....
..... [2]

(f) Explain proper storage of the following food items:

(i) Milk

.....
.....

(ii) Oranges

.....
..... [4]

(g) Windows are important features in a home and need proper care.

(i) Name **two** agents used to clean a window.

.....
..... [2]

(ii) What happens if a window is cleaned on a windy day?

.....
..... [2]

(h) Describe the importance of proper refuse disposal.

.....
.....
.....
..... [2]

[Total marks: 25]

SECTION B

This Section consists of Clothing & Textiles and Laundry.

There are **three** Questions in this section. Answer only **two** Questions.

QUESTION 4

(a) Define tailor's tacking.

.....
..... [2]

(b) Make comments on the following statements on points to consider when choosing seams:

(i) Type of fabric

.....
.....

(ii) Type of garment

.....
..... [2]

(c) State **two** points to consider when buying each of the following sewing equipment:

(i) An ironing board

.....
.....
..... [2]

(ii) Dress makers' shears

.....
.....
..... [2]

(d) Study the flat collar below and answer the questions that follow:

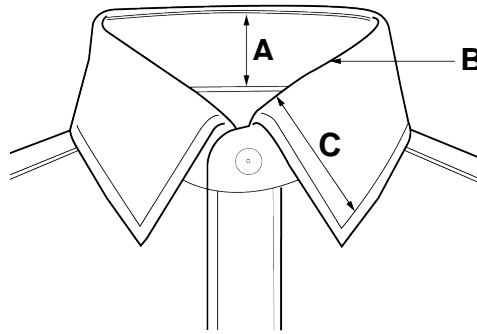

(i) Label the following parts of the collar labelled A – C.

A.....

B.....

C.....

[3]

(ii) Why is it important to apply interfacing on the collar? Give **two** reasons.

.....

.....

.....

.....

.....

[2]

(e) Give **one** point to consider when choosing laundry equipment for drying.

.....

.....

[1]

(f) State **three** reasons for ironing clothes.

.....

.....

.....

.....

[3]

(g) Outline the steps to follow when removing a candle wax stain.

.....

.....

.....

.....

.....

.....

[4]

(h) Explain, in **two** reasons, how to store clothes pegs made of wood.

*For
Examiner's
Use*

.....
.....
.....
.....
.....
..... [4]

[Total marks: 25]

QUESTION 5

(a) Give **two** suitable places where darts are sewn on a shirt.

.....
..... [2]

(b) What is the difference between an “inverted” and a “box” pleat?

.....
.....
..... [2]

(c) Name the natural fibre described by each of the processes below:

(i) Strong, durable and stronger when wet than dry.

.....

(ii) A poor conductor of heat and warm to wear.

..... [2]

(d) Match the parts of a sewing machine in list **A** with their functions in list **B** by means of arrows. An example has been done for you.

List A

- (i)** Balance wheel
- (ii)** Tension disk
- (iii)** Presser foot
- (iv)** Stitch length regulator
- (v)** Feed dog
- (vi)** Needle clamp screw

List B

- Holds the needle firmly in position
- Holds fabric firmly in position whilst sewing
- Regulates the length of the stitches
- Pushes the fabric when sewing
- Regulates the tightness of the stitches
- Controls the movement of the machine

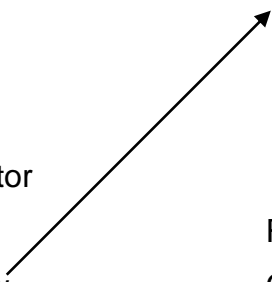

[5]

(e) State the use of each of the following hand stitches.

(i) satin stitch

..... [1]

(ii) running stitch

..... [1]

(iii) blanket stitch

..... [1]

(f) Which are the substances used to remove the following stains?

- (i) Ink
- (ii) Blood.....
- (iii) Grass
- (iv) Pain [4]

(g) Why are the following procedures important when removing stains?

- (i) Identify the cause of stain.
.....
- (ii) Remove stain before washing the garment.
..... [2]

(h) Give the importance of care labels on garments.

.....
.....
..... [2]

(i) Justify the reasons for the following when laundering woollen garments.

- (i) Empty pockets and shake woollen garment.
.....
- (ii) Darn any holes.
.....
- (iii) Measure the length and width of the garment.
..... [3]

[Total marks 25]

QUESTION 6

(a) Name **one** type of fastener suitable for a child's dress.

..... [1]

(b) Define the following terms used in Textiles.

(i) Warp

.....
.....

(ii) Weft

.....
.....

(iii) Selvedge

.....
..... [3]

(c) Give uses of the following sewing equipment:

(i) Tape measure

.....
..... [1]

(ii) Pins

.....
..... [1]

(iii) Thimble

.....
..... [1]

(d) State **two** qualities of a well-sewn dart.

.....
.....
..... [2]

(e) Differentiate between instruction sheet and a pattern adjustment line.

(i) instruction sheet

.....
.....

(ii) pattern adjustment line

.....
..... [2]

(f) Outline the steps to follow when making a plain seam.

.....
.....
.....
.....
..... [4]

(g) Give **one** reason for using a pressing cloth.

..... [1]

(h) State the reason for applying fabric softener in the last rinsing water.

..... [1]

(i) Justify why the following procedures are done when removing stains from garments:

(i) Remove stains immediately.

.....

(ii) Use stain removal agents with care.

.....

(iii) Rinse garment thoroughly after treatment.

.....

(iv) Remove stains before washing the garment.

..... [4]

(j) Explain the procedure for softening temporary hard water in a home.

.....
.....
.....
.....
..... [4]

[Total marks 25]

BLANK PAGE

BLANK PAGE

Permission to reproduce items where third party owned material protected by copyright is included has been sought and cleared where possible. Every reasonable effort has been made by the publisher (ECESWA) to trace copyright holders, but if any items requiring clearance have unwittingly been included, the publisher will be pleased to make amends at the earliest possible opportunity.